

Finished Size: 54¼" x 54¼"

FABRIC REQUIREMENTS

	<p>Fabric A 29426 C ¾ YARD</p>		<p>Fabric B 29428 Z ¾ YARD</p>		<p>Fabric C 29427 S ½ YARD</p>		<p>Fabric D 29426 B ½ YARD</p>
	<p>Fabric E 29429 J ½ YARD</p>		<p>Fabric F 9000 Black 1 ⅔ YARDS*</p>		<p>Fabric G 29430 B ¾ YARD</p>		<p>Fabric H 29424 J 1 ⅓ YARDS</p>
	<p>Fabric I 29427 J 3 ⅝ YARDS**</p>	<p>* includes Binding ** Suggested backing fabric. Not supplied with kits</p>					

Designed by: Janice Averill

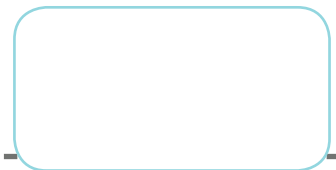

We recommend that you carefully read through all instructions before getting started on your project.

CUTTING DIRECTIONS

Note:

WOF=Width of fabric (from selvage to selvage)

Fabric A, cut

- (1) $6\frac{3}{8}$ " x WOF strip.
- (1) $3\frac{3}{8}$ " x WOF strip.

Fabric B, cut

- (1) $6\frac{3}{8}$ " x WOF strip.
 - (1) $3\frac{3}{8}$ " x WOF strip.
 - (1) $1\frac{1}{4}$ " x WOF strip.
- Subcut (4) $1\frac{1}{4}$ " x $1\frac{1}{4}$ " squares.

Fabric C, cut

- (1) $6\frac{3}{8}$ " x WOF strip.
- (1) $3\frac{3}{8}$ " x WOF strip.

Fabric D, cut

- (1) $6\frac{3}{8}$ " x WOF strip.
 - (1) $3\frac{3}{8}$ " x WOF strip.
 - (1) 2" x WOF strip.
- Subcut (4) 2" x 2" squares.

Fabric E, cut

- (8) $1\frac{5}{8}$ " x WOF strips.

Fabric F, cut

- (32) $1\frac{1}{4}$ " x WOF strips.
- Subcut (5) strips into $1\frac{1}{4}$ " x $40\frac{3}{4}$ " strips,
(7) strips into (28) $1\frac{1}{4}$ " x 10" rectangles, and
(1) strip into (8) $1\frac{1}{4}$ " x $4\frac{1}{2}$ " rectangles.
- (6) $2\frac{1}{4}$ " x WOF for binding.

Fabric G, cut

- (5) 2" x WOF strips.

Fabric H, cut from length of fabric, parallel to the selvage edges:

- (5) $4\frac{1}{2}$ " x LOF strips.
- Subcut (4) strips into $4\frac{1}{2}$ " x $45\frac{1}{4}$ " strips and
(1) strip into (4) $4\frac{1}{2}$ " x $4\frac{1}{2}$ " squares.

Fabric I, cut

- (2) 62" x WOF strips.

SEWING INSTRUCTIONS

All seams are sewn with right sides together, raw edges even and using $\frac{1}{4}$ " seam allowance.

MAKING THE STRIP SETS

1. Make (4) 10" x WOF strip sets with a $1\frac{1}{4}$ " **Fabric F** strip in the center of each with a $3\frac{3}{8}$ " top strip and $6\frac{3}{8}$ " bottom strip in the fabrics shown. Press seams toward the **Fabric F** strips. Crosscut each strip set into (8) 3" segments and label.

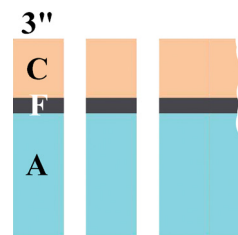

AC1 Segments
Cut 8

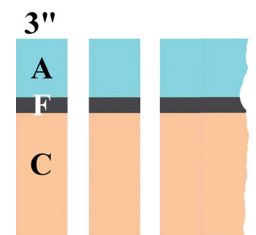

AC2 Segments
Cut 8

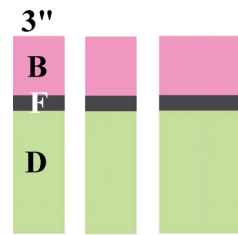

BD1 Segments
Cut 8

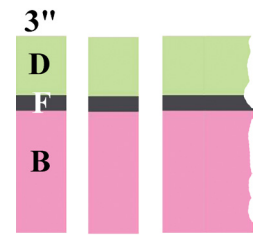

BD2 Segments
Cut 8

2. Sewing lengthwise, stitch a $1\frac{5}{8}$ " **Fabric E** strip to a $1\frac{1}{4}$ " **Fabric F** strip. Press the seam toward the **Fabric F** strip to make a $2\frac{3}{8}$ " x WOF strip set. Repeat to make a total of (8) strip sets. Cut (4) 10" segments from each strip set to yield a total of (32) segments.



EF Segments
Cut 32

BLOCK ASSEMBLY

1. Stitch A1 and B1 segments from step 1 to the long sides of a $1\frac{1}{4}$ " x 10" **Fabric F** piece, noting orientation. Press the seams toward the **Fabric F** piece. Stitch EF segments from step 2 to the top and bottom, again noting orientation. Press the seams toward the EF segments to complete (1) 10" x 10" Block A. Repeat to make a total of (8) Block A.

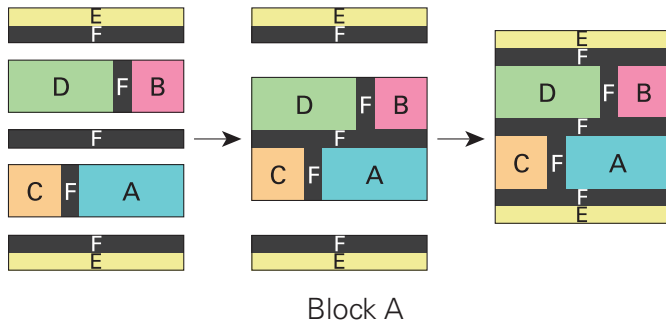

2. Stitch A2 and B2 segments from step 1 to the long sides of a $1\frac{1}{4}$ " x 10" **Fabric F** piece, noting orientation. Press the seams toward the **Fabric F** piece. Stitch EF segments from step 2 to the top and bottom, again noting orientation. Press the seams toward the EF segments to complete (1) 10" x 10" Block B. Repeat to make a total of (8) Block B.

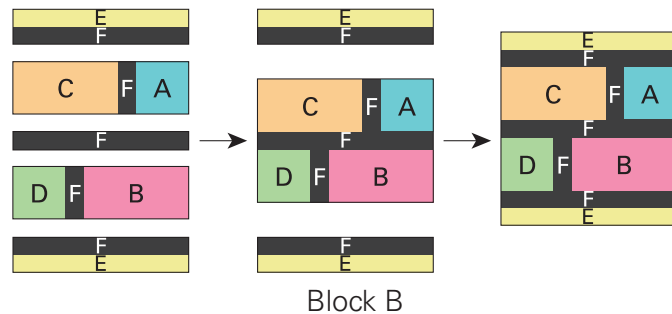

QUILT ASSEMBLY

1. Referring to the exploded quilt diagram, lay out (4) rows with (2) Block A, (2) Block B, and (3) $1\frac{1}{4}$ " x 10" **Fabric F** pieces in each row. Alternate the blocks and **Fabric F** pieces and rotate each block as shown in the diagram. Stitch into (4) rows.

2. Stitch the (4) block rows and (3) $1\frac{1}{4}$ " x $40\frac{3}{4}$ " **Fabric F** strips together, alternating the block rows with the **Fabric F** strips. Press all seams toward the **Fabric F** strips to complete the quilt center.

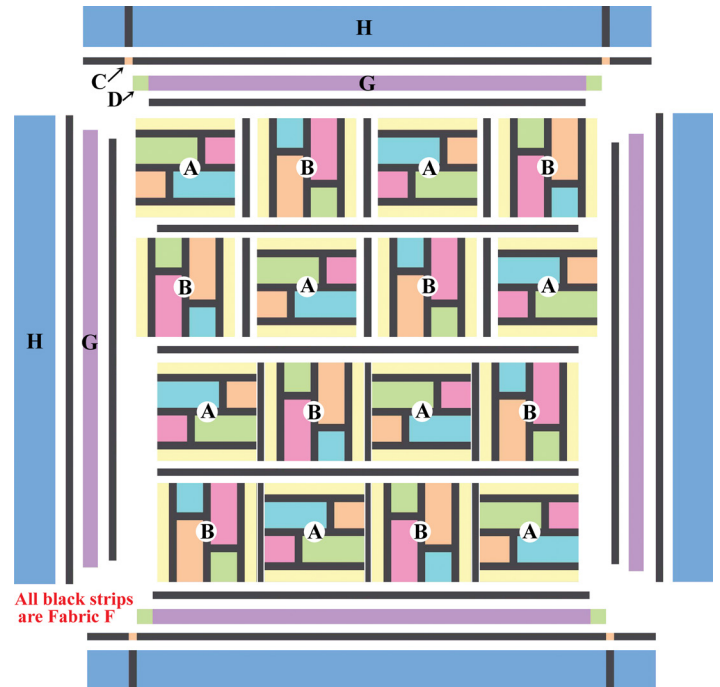

3. Stitch $1\frac{1}{4}$ " x $40\frac{3}{4}$ " **Fabric F** strips to the left and right sides of the quilt top. Press the seams toward the **Fabric F** strips.

4. Stitch together (7) $1\frac{1}{4}$ " x WOF **Fabric F** strips end to end to make a long strip. From this long strip, cut (4) $45\frac{1}{4}$ " and (2) $42\frac{1}{4}$ " lengths. Sew the $42\frac{1}{4}$ " lengths to the top and bottom of the quilt top. Press the seams toward the **Fabric F** strips.

5. Stitch together (5) 2" **Fabric G** strips end to end to make a long strip. From this long strip, cut (4) $42\frac{1}{4}$ " strips. Sew (2) strips to the left and right sides of the quilt top. Sew 2" **Fabric D** squares to the ends of the remaining **Fabric G** strips. Sew the pieced border units to the top and bottom of the quilt.

6. Sew (2) of the $45\frac{1}{4}$ " **Fabric F** strips cut in step 4 to the left and right sides of the quilt top. Press the seams toward the **Fabric F** strips.

7. Stitch $4\frac{1}{2}$ " x $45\frac{1}{4}$ " **Fabric H** strips to the sides of the quilt top. Press seams toward the strips.

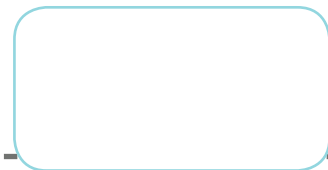

8. Sew 1¼" **Fabric C** squares and then 1¼" x 4½" Fabric F strips to the ends of the remaining 1¼" x 45¼" **Fabric F** strips. Press seams toward the **Fabric F** strips. Stitch the border units to the top and bottom of the quilt top. Press seams toward the border units.

9. Stitch 1¼" x 4½" **Fabric F** strips and then 4½" **Fabric H** squares to the ends of the remaining 4½" x 45¼" **Fabric H** strips. Press seams toward the **Fabric F** strips. Sew the border units to the top and bottom of the quilt. Press seams toward the border units.

FINISHING

1. Prepare a 62" x 62" backing piece. Layer the completed quilt top with batting and backing and quilt as desired. Trim edges even.

2. Bind the finished quilt with the 2¼" **Fabric F** strips

While all possible care has been taken to ensure the accuracy of this pattern, we are not responsible for printing errors or the way in which individual work varies.